

Nailed Structural-Use Panel and Lumber Beams

When roof load or span requirements are too great to allow use of commonly available dimension lumber or timbers, a box beam constructed of lumber and APA trademarked structural-use panels can solve the problem. It offers an inexpensive alternative to steel or glued laminated wood beams.

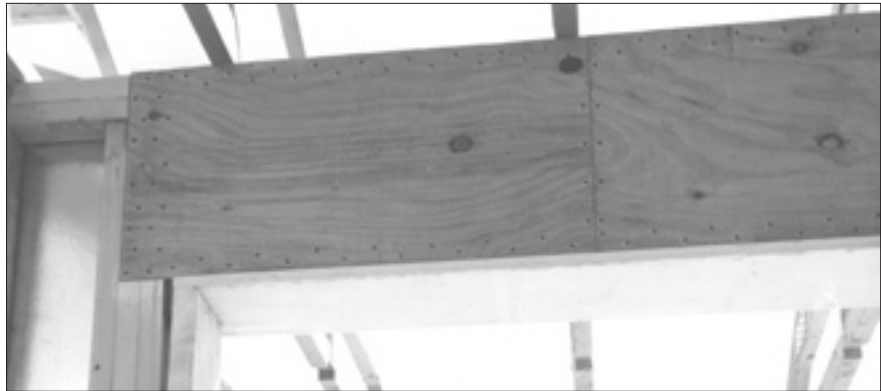

Nailed structural-use panel and lumber beams have many other advantages, too. Among them are:

- Stiffness and strength
- Light weight
- No shrinkage, warping, or twisting
- Ease of fabrication
- Materials availability
- Speedy, easy installation
- Easily insulated, where necessary

Parts of a box beam are shown in the diagram. The lumber flanges carry most of the bending stresses and the structural panel webs transmit the shear stresses. Vertical stiffeners between the flanges act as shear splices at panel butt joints, distribute concentrated loads and end reactions, and resist web buckling. The fasteners transfer the stresses between the lumber and panel parts.

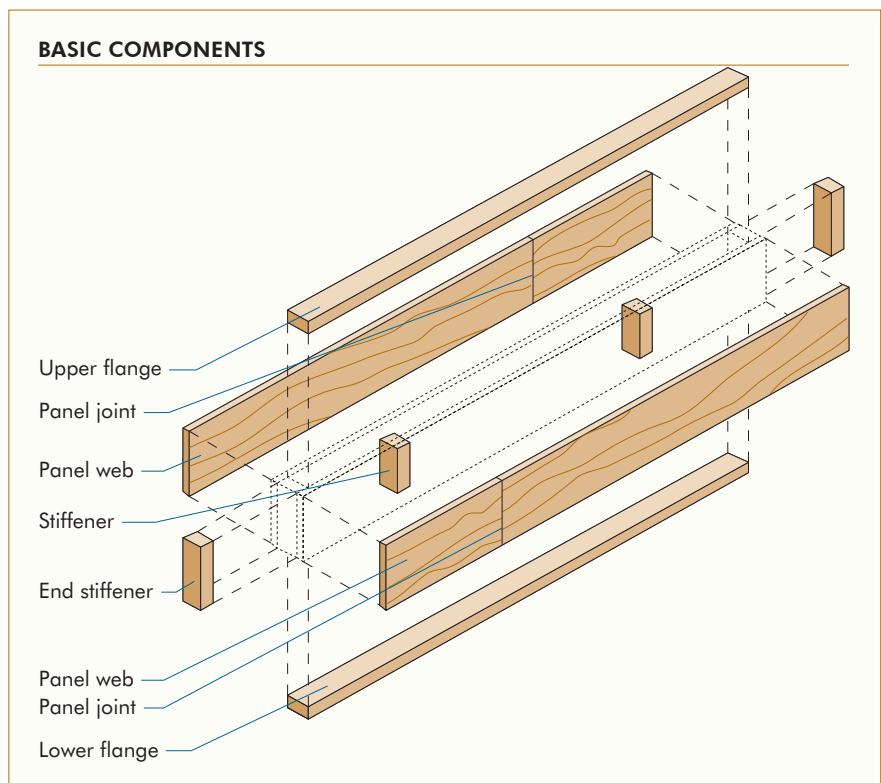

These tables show allowable loading for two typical thicknesses and Span Ratings of structural panels. The Span Rating, a set of two numbers separated by a slash (for example, 32/16), is contained in the APA trademark for structural panel sheathing grades.

In the first column of each table, the minimum nominal panel thickness is given first, followed by the Span Rating number.

The cross-sections – A, B, and C – refer to the constructions shown in the sketches. The loads in the tables are given in pounds per linear foot. The lumber and structural panel grades used for calculating the tables are:

Lumber: 2 x 4 or 2 x 6 No. 1 Douglas-fir or No. 1 southern pine (unless otherwise noted, reduce allowable loads by 15 percent for No. 2 Douglas-fir or No. 2 southern pine).

Structural Panels: APA RATED SHEATHING Exposure 1, oriented strand board (OSB), composite panels (COMPLY®), 4- or 5-ply plywood. Three-ply plywood may be used if regraded for core gap restrictions (see item 3 in the Fabrication section).

ALLOWABLE LOADS^(a) FOR 12-INCH DEEP ROOF BEAMS OR HEADER (lb/ft)

Panel Specification	Cross Section	Approx. Wt. per ft (lb)		Span (ft)							
		2 x 4	2 x 6	10	12	14	16	18	20	22	24
15/32" 32/16	A	6	8	238*	198*	170*	147	116	94	78	64
15/32" 32/16	B	9	12	339*	283*	242*	212	176	143	118	91
23/32" 48/24	B	11	14	408*	340	291	223	176	143	118	95
23/32" 48/24	C	13	17	374*	312*	267*	234	198	160	133	105

ALLOWABLE LOADS^(a) FOR 16-INCH DEEP ROOF BEAMS OR HEADER (lb/ft)

Panel Specification	Cross Section	Approx. Wt. per ft (lb)		Span (ft)							
		2 x 4	2 x 6	10	12	14	16	18	20	22	24
15/32" 32/16	A	8	10	336*	280*	240*	210	166	134	111	93
15/32" 32/16	B	10	13	475*	396*	340*	297	264	219	181	152
23/32" 48/24	B	13	16	569*	474*	406	342	270	219	181	152
23/32" 48/24	C	15	19	531*	443*	380*	332*	295	266	219	184

ALLOWABLE LOADS^(a) FOR 20-INCH DEEP ROOF BEAMS OR HEADER (lb/ft)

Panel Specification	Cross Section	Approx. Wt. per ft (lb)		Span (ft)							
		2 x 4	2 x 6	10	12	14	16	18	20	22	24
15/32" 32/16	A	9	11	440*	367*	315*	273	216	175	144	121
15/32" 32/16	B	12	15	610*	509*	436*	381*	339	297	246	207
23/32" 48/24	B	15	18	728*	607*	520	455	367	297	246	207
23/32" 48/24	C	17	22	693*	577*	495*	433*	385*	346	312	262

ALLOWABLE LOADS^(a) FOR 24-INCH DEEP ROOF BEAMS OR HEADER (lb/ft)

Panel Specification	Cross Section	Approx. Wt. per ft (lb)		Span (ft)							
		2 x 4	2 x 6	10	12	14	16	18	20	22	24
15/32" 32/16	A	11	13	550*	458*	393*	336	266	215	178	149
15/32" 32/16	B	13	16	744*	620*	531*	465*	413	372	312	262
23/32" 48/24	B	16	20	885*	738*	632*	553	465	377	312	262
23/32" 48/24	C	18	24	854*	711*	610*	533*	474*	427	388	342

(a) Includes 15% snow loading increase.

*Lumber may be No. 2 Douglas-fir or No. 2 southern pine without reduction of tabulated capacity.

Substitution of higher grades or thicknesses may not result in higher allowable loads, depending upon what limitation controls the design. Also, the calculations assume full-length flange lumber. For this reason, beam length is usually limited to that of available lumber.

CROSS SECTIONS

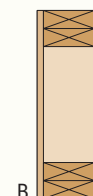
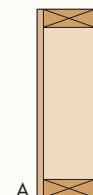

Tables are also based on the following:

Deflection: Less than 1/240 of span under total load.

Nailing: 8d common (0.131 inch x 2-1/2 inches) 1-1/2 inches o.c. each flange member (spacing may be doubled in middle half of beam).

DESIGN

In order to build a box beam that will do the job, you must first determine the load requirements. Here is an example.

1. Calculate the load on a beam.

Assume that a header using 2 x 4 lumber is to span an 18-foot garage door opening, where the roof is supported by 20-foot-long trusses, including a 1-foot eave on each end.

The total roof load consists of 25 psf design snow load (check your local building code) plus 10 psf dead load, which is the weight of the materials in the roof. This total load of 35 psf is carried to the garage-door header and to the back wall of the garage. Thus, the design load on the header is:

$$35 \text{ psf} \times \frac{20 \text{ ft}}{2} = 350 \text{ plf}$$

2. Find the appropriate beam design.

Look in the 18-foot-span column of the load-span tables and find a beam adequate to support 350 plf plus the weight of the beam. Such a beam is 24 inches deep and consists of two 2 x 4 flange members top and bottom (cross section B), and 15/32-inch structural panel webs. This beam has an allowable load of 413 plf. The total load on this beam will be 350 plf plus 13 plf, or 363 plf.

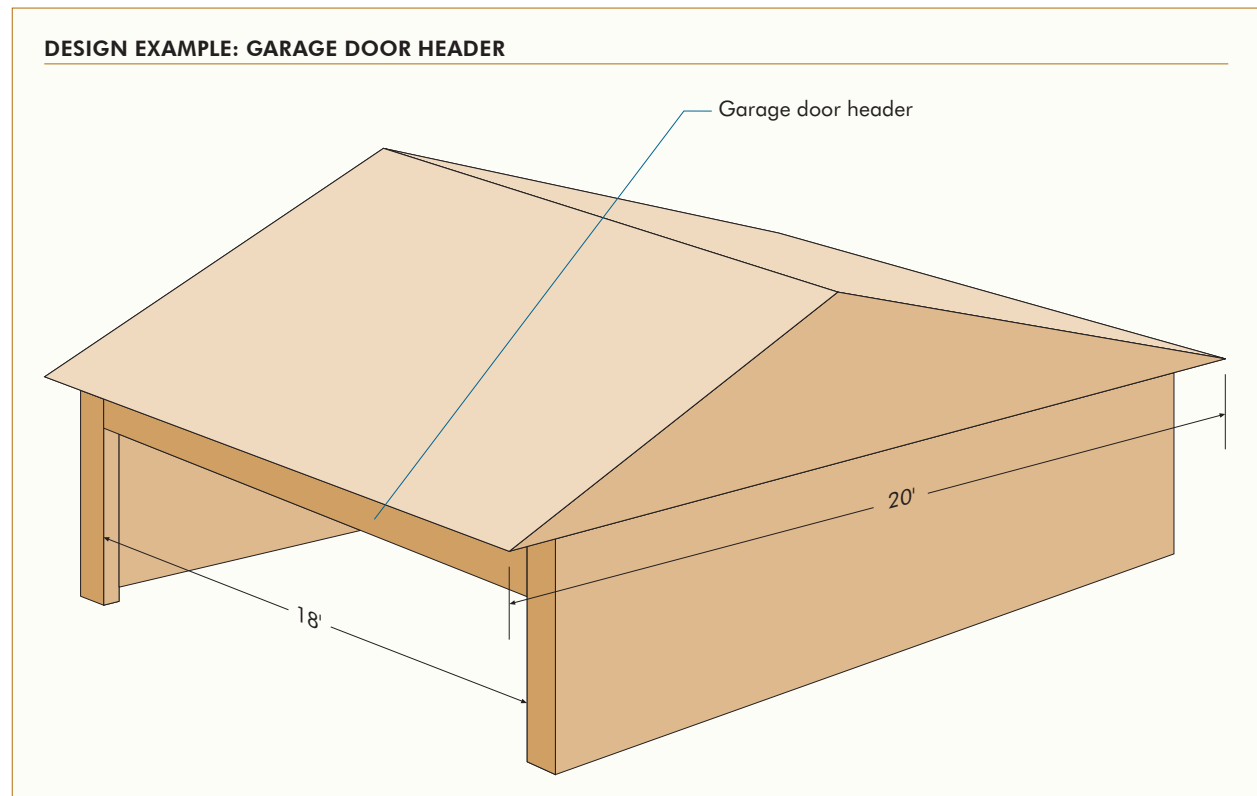

FABRICATION

There are just three simple steps in constructing a structural panel-and-lumber box beam.

1. Determine the width of framing lumber necessary to match wall thickness and layout of stiffeners and the panel butt joints.

The panel joint locations illustrated in the sketches provide the required minimum 2-foot stagger between panel butt joints on opposite sides of the beam. They also locate all butt joints within the middle half of the beam. This technique allows the stiffeners to act as web shear splices. Vertical stiffeners should be added in the layouts so that they are no farther apart than 4 feet.

The 6 inches (0.5 foot) added to the clear spans shown in the load-span tables represent the bearing length of both double end stiffeners.

2. Build the framework of lumber flanges and stiffeners.

Dry lumber should be used (not over 19 percent moisture content). Select full-length flange lumber which is free of warp or characteristics that would produce gaps greater than 1/8 inch between lumber and structural panel.

Lay out stiffeners and flanges accurately in the pattern selected in Step 1. Fasten the flanges to the stiffeners with 8d common (0.131 inch x 2-1/2 inches) nails.

Double end stiffeners may be installed between flanges. Frequently, however, it is desirable to extend the end stiffeners through the depth of the beam to allow use of shorter-length flange lumber. On other occasions, it may be desirable to extend the top flange lamination beyond the beam end to tie into the wall framing.

3. Fasten the panel webs to the framework.

If 3-ply plywood is to be used, inspect the plywood panels within 15 percent of each end of the box beam to assure that no core gap exceeds 1/4-inch width.

WEB JOINT LAYOUTS

10' to 10-1/2'

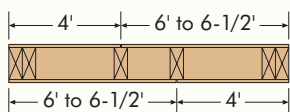

12' to 12-1/2'

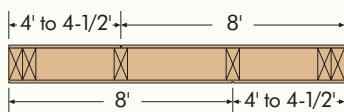

14' to 14-1/2'

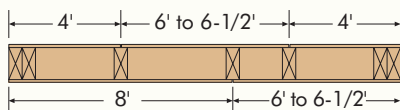

16' to 16-1/2'

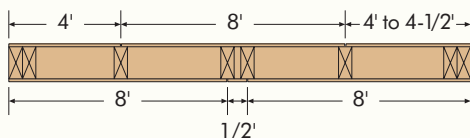

18' to 18-1/2'

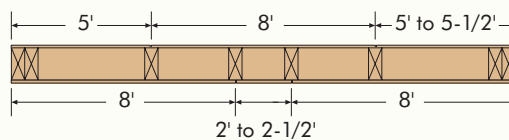

20' to 20-1/2'

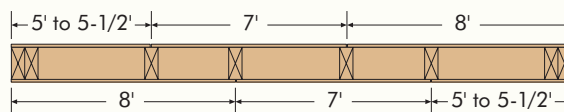

22' to 22-1/2'

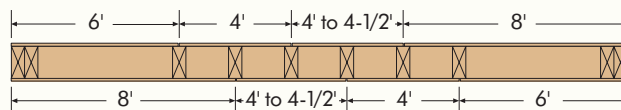

24' to 24-1/2'

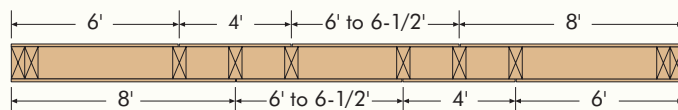

NAILING LAYOUT

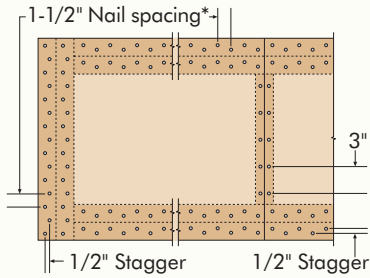

*When end stiffeners extend through the beam, nail spacing is the same as for flanges, except space nails **1 inch on center** when double end stiffeners are used in beams with three members per flange (cross-section C). When end stiffeners are inserted between flanges, nails may be spaced 3 inches on center.

The flanges should be marked to show location of stiffener centerlines. The panel should be installed with its strength axis in the same direction as the flanges, and with the butt joints occurring over the stiffeners, as determined in Step 1.

All beams in the load-span tables function with 8d common (0.131 inch x 2-1/2 inches) nails spaced 1-1/2 inches on center on each side of each flange lamination. The spacing may be doubled to 3 inches on center in the middle half of the beam. Use corrosion-resistant nails if the beam is exposed to moisture. If staples, or nails of other sizes or types are used, the spacing must be adjusted in proportion to the allowable lateral load for the fasteners selected. For instance, fasteners allowed half the lateral load of 8d common (0.131 inch x 2-1/2 inches) nails would be spaced half as far apart. For staples, the closer spacing can be used because there is less tendency to split the lumber.

Although the nailing shown is structurally adequate for loads presented in the tables, additional stiffness can be developed by including glue at the interfaces. Any type of available wood adhesive will contribute to performance, but do not use it instead of any of the nails required in the design.

APA: THE MARK OF QUALITY

The trademarks of APA – *The Engineered Wood Association* appear only on products manufactured by APA member mills. The marks signify that the manufacturer is committed to APA’s rigorous quality inspection and testing program and that panel quality is subject to verification through APA audit – a procedure designed to assure manufacture in conformance with APA performance standards or *Voluntary Product Standard PS 1-07 for Structural Plywood*. Always insist on panels bearing the **mark of quality** – the APA trademark.

HEADER ATTACHMENT DETAILS

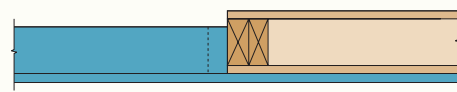

Sheathing or siding over; or set beam out thickness of sheathing and butt sheathing to web.

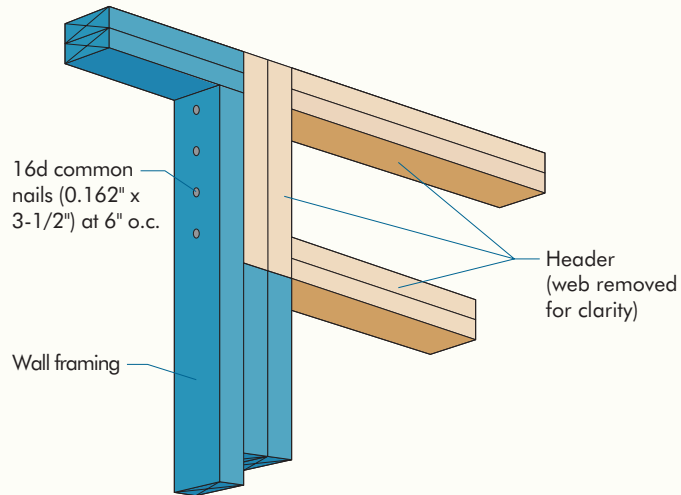

ALTERNATE TOP FLANGE SUPPORT

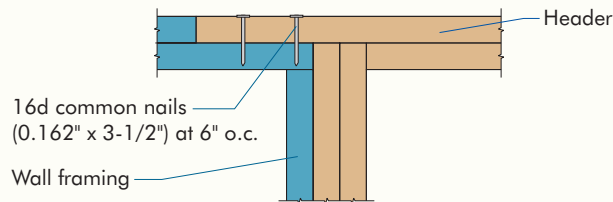

THICKNESS 0.451 IN.

APA

RATED SHEATHING
32/16
SIZED FOR SPACING
EXPOSURE 1
000

APA PS1-07
15/32 CATEGORY

Nailed Structural-Use Panel and Lumber Beams

We have field representatives in many major U.S. cities and in Canada who can help answer questions involving APA trademarked products. For additional assistance in specifying engineered wood products, contact us:

APA HEADQUARTERS

7011 So. 19th St. ■ Tacoma, Washington 98466 ■ (253) 565-6600 ■ Fax: (253) 565-7265

PRODUCT SUPPORT HELP DESK

(253) 620-7400 ■ E-mail Address: help@apawood.org

DISCLAIMER

The information contained herein is based on APA – The Engineered Wood Association’s continuing programs of laboratory testing, product research and comprehensive field experience. Neither APA, nor its members make any warranty, expressed or implied, or assume any legal liability or responsibility for the use, application of, and/or reference to opinions, findings, conclusions or recommendations included in this publication. Consult your local jurisdiction or design professional to assure compliance with code, construction and performance requirements. Because APA has no control over quality of workmanship or the conditions under which engineered wood products are used, it cannot accept responsibility for product performance or designs as actually constructed.

Form No. Z416T/Revised February 2009



REPRESENTING THE ENGINEERED WOOD INDUSTRY